

# 17VXE



## DIGGING DEPTH

7'0"

## BUCKET WIDTH

18"

## OPERATING WEIGHT

3,583 LBS

# KATO

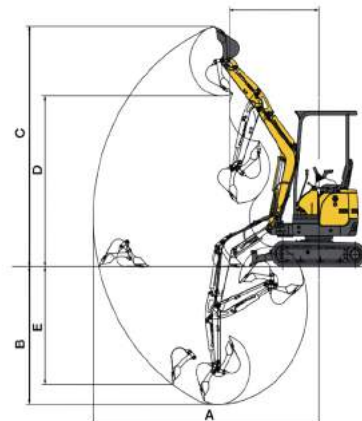
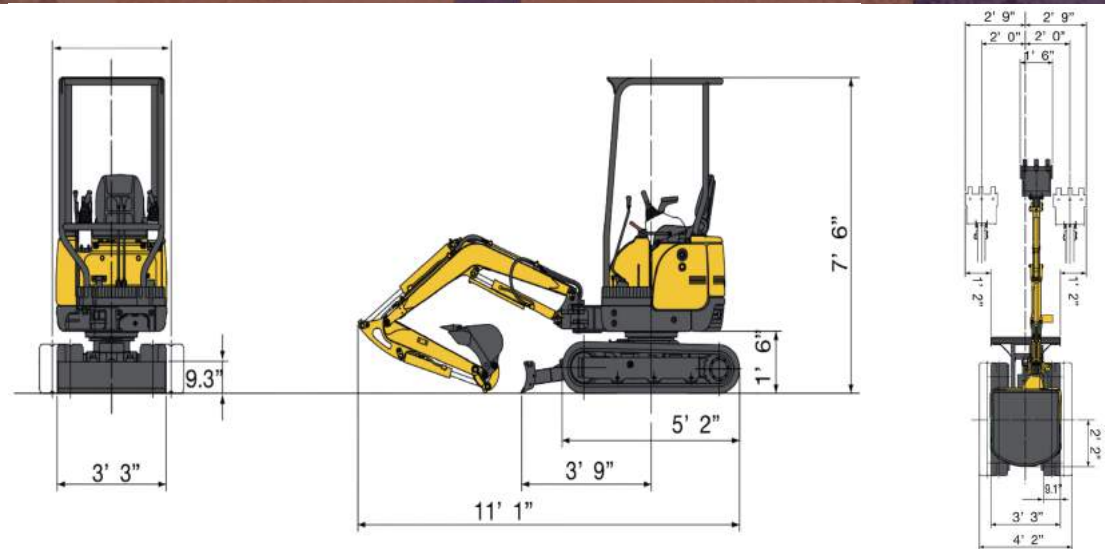

## 17VXE

### Working Ranges

A.	Max. digging radius	12'4"
B.	Max. digging depth	7'0"
C.	Max. digging height	11'10"
D.	Max. dumping height	8'5"
E.	Max. vertical digging depth	5'10"
F.	Min. front turning radius	4'11"
G.	At right boom swing	4'2"

# 17V 17VXE

MODEL	17VXE
<b>Performance</b>	
Bucket capacity	1.6 cu. ft.
Bucket width	18"
Operating weight: 4-Post	3,583 lbs
Transportation weight: 4-Post	3,417 lbs
Swing speed	9.5 min <sup>-1</sup>
Travel speed (low\high)	1.3\ 2.5 mph
Gradeability	30°
Ground pressure	3.8 psi
Max.bucket digging force	5,447 lbs
<b>Engine</b>	
Motor	Ruesland 15 H.P. 3PH 480V
<b>Boom swing system</b>	
Type	Boom offset with hydraulic cylinder
Swing angle (L\R)	50°\80°
<b>Hydraulic system</b>	
Pressure	3,000 psi
Pump* Type/ Hydraulic Flow	2 Piston/ 2 Gear*4.5 gal./ min x 2 + 3.2 gal/min
Max Auxiliary Hydraulic Flow	7.7 gal/min
<b>Dozer blade</b>	
Size	37.8* x 9.3*
Lift above ground\ Drop below ground	10.8"/12"

# KATO

**EXCAVATORS AND TRACK LOADERS**

[www.KATOCES.com](http://www.KATOCES.com)

**400 Production Court**

**Elizabethtown, KY 42701**

**(800) 538-1447 | Fax: (270) 737-0419**