

IC70R-Crawler Carrier



PAYLOAD

15,000 LBS

OUTPUT RATING

188 HP

TRANSPORT WEIGHT

25,408 LBS

KATO

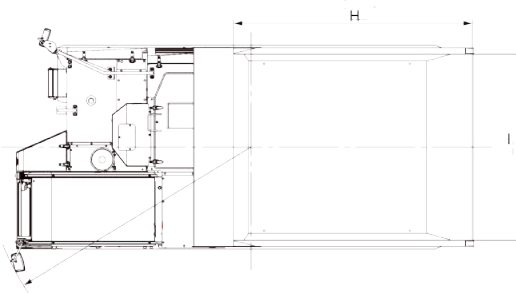
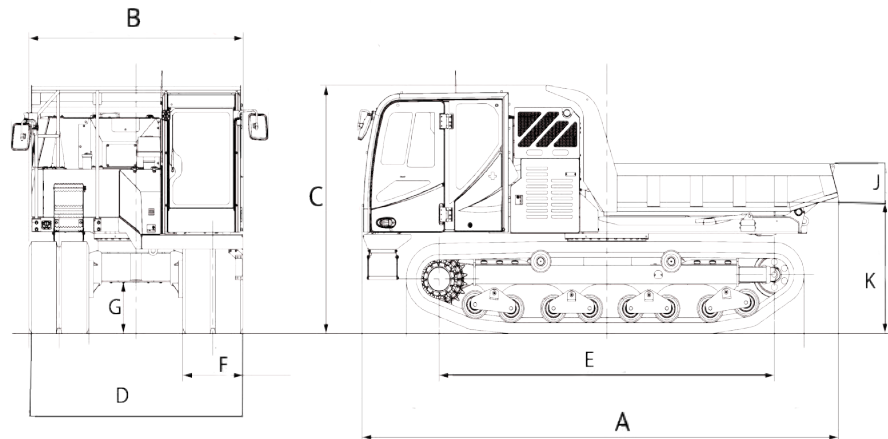

IC70R-Crawler Carrier Working Ranges

A.	Overall length	18'2"
B.	Overall width	9'9"
C.	Overall height	8'10"
D.	Overall crawler width	8'2"
E.	Tumbler center distance	12'9"
F.	Crawler track width	2'4"
G.	Minimum ground clearance	1'10"
H.	Vessel length	9'4"
I.	Inner vessel width	7'6"
J.	Vessel height	16.9"
K.	Vessel floor height from ground	4'7"
L.	Max dump height	14'11"

***Continuous 360° rotation**



MODEL	IC70R
Performance	
Transport Weight	25,408 lbs
Payload	15,000 lbs
Ground Pressure (Empty/ Loaded)	3.64 psi/ 6.17 psi
Travel Speed (Low/High)	5.0/7.5 MPH
Gradeability	20 Degrees
Engine	
Model	Kubota V5009
Rated Output	188 HP
Fuel Tank Capacity	75.2 Gallons
Def Tank Capacity	10.6 Gallons
Vessel	
Style	Boat-shaped scoop end
Capacity	4.00 yards ³
Dimensions LxWxH	9'5" x 7'6" x 1'5"
Maximum Dump Angle	65°



www.KATOCES.com

400 Production Court

Elizabethtown, KY 42701

(800) 538-1447 | Fax: (270) 737-0419